



## Installation Instructions

### MegaShots 2:1:2 system

# '86-up Harley-Davidson FLH/FLT High Performance Big Bore V-Twins



**827-71967** Chrome head pipe with Black Ceramic heat shields

**828-71967** Chrome head pipe with Chrome heat shields



**CAUTION:** Before attempting to install this exhaust system, make sure the motorcycle is cool and placed securely on a service lift or jack stand.



**WARNING:** You must use the conical shaped exhaust gaskets (HD part #65324-83A), stock Harley-Davidson flanges and snap rings with this exhaust system. **DO NOT** use the flat type exhaust gaskets with our head pipe.

### STOCK SYSTEM REMOVAL:

1. Remove the right side floorboard and retain for new system installation.
2. Remove the stock exhaust system as described in your service manual. Retain the flange nuts for the new system installation.
3. Remove the stock snap rings and flanges from the head pipes and retain for the new system installation. **NOTE: Replace snap rings if cupped or twisted and do not seat properly in the flange. (HD part number 65325-83A).**
4. On **2007** and later models: Remove the oxygen sensors from the front and rear head pipes and retain for new system installation.
5. Remove the plastic heat shield under the seat on models with this option. (See Figure 1).
6. On **2006** and earlier models, remove the stock transmission mount bracket. (See Figure 2). **2007** and later models will use the stock mounting bracket.
7. Install new exhaust gaskets to achieve a proper fit and seal.

### SYSTEM INSTALLATION:

1. Mount discs/end cap on mufflers. *See tuning & disc installation on the next pages.*
2. Install stock flanges and snap rings on head pipe inlets.
3. On model years **2006** and earlier loosely install supplied transmission mount bracket in stock location using bolts supplied in hardware kit. **DO NOT TIGHTEN.** (See Figure 3) For model years **2007** and up use the stock transmission bracket and carriage bolt.
4. On **2007** and up, apply a **very light coating** of anti-seize to the threads of the oxygen sensors and install in new head pipes. (**VERY IMPORTANT:** Apply anti-seize to the threads of the oxygen sensor **ONLY**. Contamination of the sensor probe can adversely affect engine performance.) **NOTE: The oxygen sensor connectors are color coded for proper installation. The GRAY connector is for the FRONT head pipe sensor and the BLACK connector is for the REAR head pipe.**
5. All models, install supplied oxygen sensor plugs with anti-seize into the oxygen sensor ports not being used.
6. Loosely install the front and rear heat shields using the #28 hose clamps supplied in hardware kit (3 for each heat shield). Install the hose clamps, so there is easy access to tighten after head pipe is installed on bike. **DO NOT TIGHTEN COMPLETELY.**
7. Mount the head pipe using the stock flange nuts. On model years **2007** and later, loosen the factory transmission mounting bracket for ease of installing head pipe. **On all models the head pipe mount bracket mounts under the transmission bracket. DO NOT TIGHTEN.**
8. On **2006** and earlier models, slide the supplied 3/8-16" x 1.25" bolt and flat washer through the slot in the transmission mount bracket and head pipe mount. Fasten with the supplied 3/8" flat washer, 3/8"-16" nylock nut. On **2007** and later models install the factory carriage bolt and nut through both mounting brackets. **DO NOT TIGHTEN COMPLETELY.**
9. Slide one of the T-bolt clamps (supplied) onto the inlet end of one of the mufflers. Slide the muffler onto the outlet end of the head pipe. **DO NOT TIGHTEN CLAMP.**

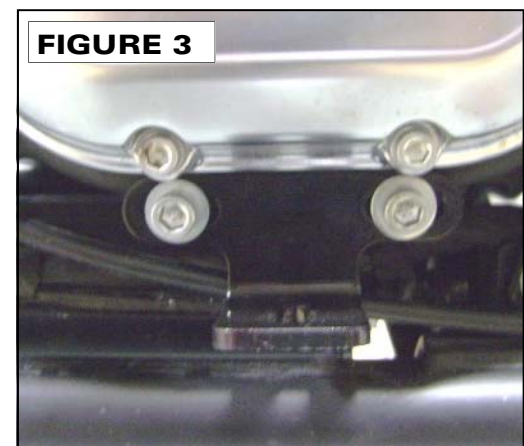
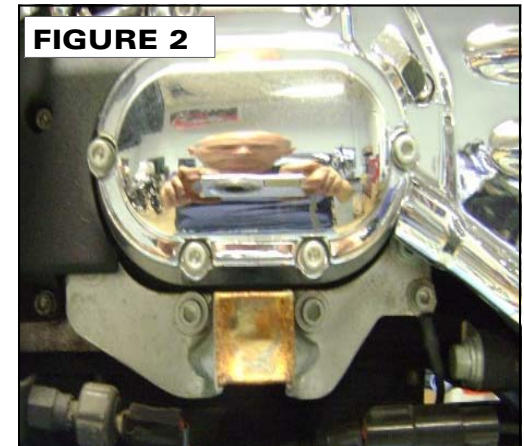

10. Attach the muffler to the stock muffler support using the stock 5/16" bolts and lock washers. Tighten both bolts.
11. **2009** and later models, install the supplied crossover support bracket on the back of the transmission in the stock location. **See Figure 4.** Tighten the two socket head bolts completely.
12. Slide a T-bolt clamp (supplied) onto the slotted end of the crossover pipe and install onto the crossover outlet of the head pipe. Tighten the clamp just enough to keep the crossover in place but loose enough to still move it for alignment.
13. **2009** and later models, slide the 2.125" P-clamp (supplied) onto the crossover pipe as shown in **Figure 4.** Fasten the P-clamp to the bracket with a 3/8-16" x 1.25" bolt, (2) flat washers, and a 3/8-16" nylock nut (supplied). **DO NOT TIGHTEN COMPLETELY.**
14. Slide a T-bolt clamp (supplied) onto the other muffler and install onto the crossover pipe. Attach the muffler to the stock muffler support using the stock 5/16" bolts and lock washers. Tighten completely. Tighten the T-bolt clamp till the muffler is snug but still can move.
15. Start to tighten all fasteners. Begin with the two bolts holding the exhaust mount bracket to the transmission (**See Figure 3**). Do not tighten the 3/8" bolt at this time.
16. Tighten the head pipe port flanges evenly while aligning the head pipe so the two mount brackets at the transmission bracket sit flush with each other.
17. Align the right side muffler so it is going onto the head pipe straight. The muffler should be inserted over the entire flared area of the head pipe. Do not mount the muffler so it is past the flared section of the pipe, this may cause a leak. Tighten the T-bolt clamp completely.
18. With the head pipe and right side muffler aligned, tighten the bolt at the transmission mount.
19. Align the left side muffler and the crossover pipe and tighten both T-bolt clamps. Again, do not insert muffler past the flared portion of the crossover pipe, this may cause a leak. **2009** and later models, tighten the 3/8" bolt holding the P-clamp to the lower transmission mount completely.
20. Slide the hose clamps into the slots on the back of each heat shield. Orient the clamps to gain easiest access to tighten them while in position.
21. Adjust the front and rear heat shields (already installed) on the head pipes and tighten the hose clamps. Install the straight right rear heat shield and tighten. Install the collector heat shield so it fits over each head pipe heat shield and tighten the hose clamps. Finally, install the left side crossover heat shield and tighten.
22. Re-install the floorboards with proper model year spacer kit supplied with our system. Tighten to factory specifications.
23. Clean the entire system with a good quality class cleaner to remove all dirt and finger prints before starting your bike.
24. Re-install the plastic heat shield under the seat (See Figure 1). Check to make sure you have 1/4" clearance between this shield and the rear head pipe heat shield. If not, trim the plastic for proper fit.

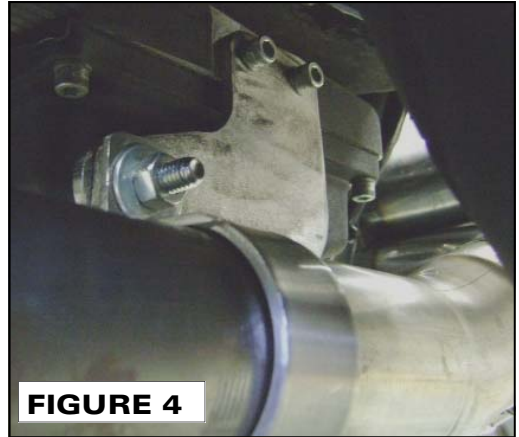

**WARNING: AFTER A SHORT RIDE CHECK AND RETIGHTEN ALL FASTENERS.**

We **DO NOT** suggest removing the muffler packing material to “get more noise”. Removing the packing will result in a loss of power, discoloration of the finish on the muffler, and potential failure of the core .

## TUNING TIPS:

Supertrapp achieved the best performance results on **modified** engines of 103 cubic inches and larger using 26 discs and closed end cap. Depending on the modifications of your engine, the number of disc will vary. To achieve maximum performance gains, we recommend having your bike Dyno tuned by a certified technician.

### END CAP & DISC INSTALLATION:

1. Stand the muffler on the bench with the outlet end pointing up.
2. Place the appropriate amount of discs and end cap on the outlet of the muffler. The flat surface of the discs should be against the core with the outer lip angled away from the muffler. Align the (6) screw holes with the threaded inserts in the muffler outlet. (SEE DIAGRAM)
3. Insert the screws through the end cap and discs and into the threaded inserts in the muffler outlet. (SEE DIAGRAM)
4. Tighten the screws evenly in a cross pattern, SEE DIAGRAM. 4” discs should be tightened to 15-25 in/lbs and 5” discs to 40-50 in/lbs or once the screw head contacts the end cap tighten 2 full turns.

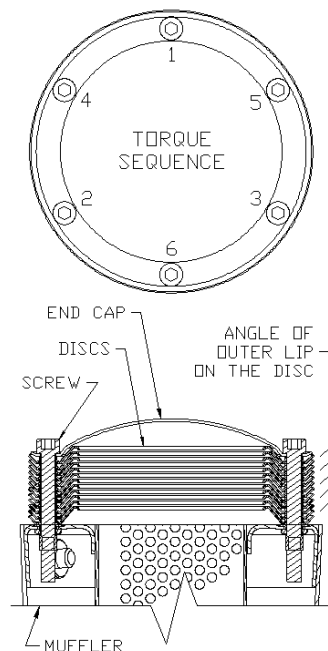

### USE AND WARRANTY DISCLAIMER

SuperTrapp Industries, Inc. of 4540 W. 160th Street, Cleveland, Ohio 44135 (SuperTrapp), warrants its products against defects in factory materials and workmanship for one year from the date of purchase or until ownership in the product is transferred, whichever occurs first, subject to limitations below. Under this warranty, SuperTrapp will repair or replace defective, covered parts, at option, or provide a replacement unit. SuperTrapp makes no warranty with respect to components of the SuperTrapp product not manufactured by SuperTrapp, including, but not limited to the following: clamps, nuts, bolts, packing, boots and hoses. Repair by SuperTrapp or replacement are the exclusive remedies under this written warranty or any implied warranty. SuperTrapp will not pay for the cost of removal or re-installation of the unit from any vehicle or for delivery and pick up of the unit. To obtain service under this warranty, the original purchaser must give specific written notice to his or her dealer within fifteen (15) days after discovery of any claimed defect in the unit, and must return such unit to the dealer within a reasonable time thereafter at the cost of the original purchaser. This limited warranty is the only express warranty applicable to SuperTrapp product. Any implied warranty of merchantability or fitness for a particular purpose is limited in duration to the duration of this written warranty. Some states do not allow limitations on how long an implied warranty lasts, so the above limitation may not apply to you. SuperTrapp shall not be responsible for any consequential, special or incidental damages of any nature including but not limited to the loss of use of any vehicle on which the unit may be installed and the cost of obtaining another substitute product. Some states do not allow the exclusion or limitation of incidental or consequential damages so this limitation or exclusion may not apply to you. This warranty is valid only if proper size of the unit is installed, operated and maintained in accordance with factory instructions. This warranty does not cover any damage caused by (i) modification or alteration of the unit; (ii) improper installation, maintenance, operation or use; (iii) accident; (iv) servicing or repair by anyone other than SuperTrapp or its authorized agents. CAUTION!: Warranty does not cover chrome discoloration. You can minimize this problem by thoroughly cleaning and polishing the system before initial start-up, being sure the fuel mixture is not too lean, and preventing long periods of engine idle. This warranty gives you specific legal rights and you may also have other rights which vary from state to state. Outside the United States, a different warranty may apply. For details, please contact your authorized SuperTrapp distributor.

*Since 1975, SuperTrapp has built a reputation on innovation and technical superiority. SuperTrapp® R&D is constantly designing, testing and improving; providing you with the latest in state of the art performance engineering. SuperTrapp® products are absolutely the best*

SuperTrapp® Industries, Inc.  
4540 W. 160th St. Cleveland, OH 44135  
Phone: (216) 265-8400 fax: (216)265-0130  
E-mail: sales@SuperTrapp.com  
www.SuperTrapp.com

