

PARTS LIST

*Hardware Kit	010-6538
*Headpipe Assembly	050-6538
*S-Bend	047-6538
Muffler Assembly	100-6282
Muffler (Shell only)	100-6228
Replacement Core with Cap	100-6397
Fiberglass Re-Pack Kit	100-8030
Baffle Cap	100-8014
Competition Core with Baffle Cap	100-6395
Competition Baffle Cap	100-8014
*Factory Order Only	

MAINTENANCE

Periodic inspection of the baffle packing is necessary to insure maximum efficiency (for both sound reduction and flow). This should be performed at every other oil change or 4,000 miles.

After removing baffle, make sure the perforated section is completely covered with packing. Repack Kit, Part No. 100-8030, is available from your dealer. Secure with masking tape to ease installation.

CUSTOMER SERVICE

If you have any problems or questions, please call our technical support staff between 8:00 AM - 12:00 PM and 1:00 PM - 5:00 PM Eastern Time. Phone:216-265-8400 Fax:216-265-0130

KERKER®

4:1 K SERIES STAINLESS SYSTEM

Kawasaki

GPZ 550

Part Number: 123-65552

KERKER EXHAUST PRODUCTS

4540 W 160th STREET, CLEVELAND OHIO 44135
PHONE: 216-265-8400 FAX 216-265-0130

STOCK SYSTEM REMOVAL

1. Remove exhaust flange fasteners at cylinder head.
2. Remove rear exhaust mount fasteners and remove exhaust system.
3. Save stock gaskets

INSTALL CENTERSTAND STOP

1. Place bike on centerstand.
2. Remove left center stand pivot bolt. Discard bolt.
3. Insert 1.10" long spacer through centerstand pivot. See Fig 1
4. Insert 10mm-1.25 X 50mm long hex bolt through center stand stop, center stand pivot, .140 spacer and secure with stock lock nut. See Fig 1

KERKER SYSTEM INSTALLATION

1. Inspect old exhaust gaskets and replace if necessary.
2. Install stock flanges onto header pipes with recessed area towards engine and allow them to slide down.
3. Install 2 stock split collars onto each headpipe (Fig 2). Note: A strip of tape wrapped around the collars will hold the in place before installation of the headpipe.
4. Install headpipes into exhaust ports while rotating flanges into position.
5. Install stock flange nuts finger tight.
6. Install small t-bolt clamp over slotted end of S-bend. Slide S-bend onto headpipe collector. Do Not Tighten

SILENCER INSTALLATION

1. Insert 5/16"x 5/8" screw with lock washer through Silencer Mount Strap and thread into square slide nut (Fig 3). Do Not Tighten.
2. Slide T-bolt clamp over silencer inlet and slide onto S-bend. Do Not Tighten.
3. Align mount strap with stock mount and install stock hardware as shown in Figure 2. Do Not Tighten.
4. Rotate S-bend as necessary to prevent binding then tighten in this order: Silencer Mount Strap, T-bolt Clamp, S-bend T-bolt clamp, and header flange nuts.

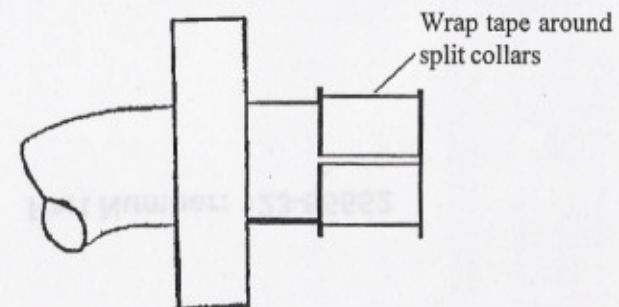
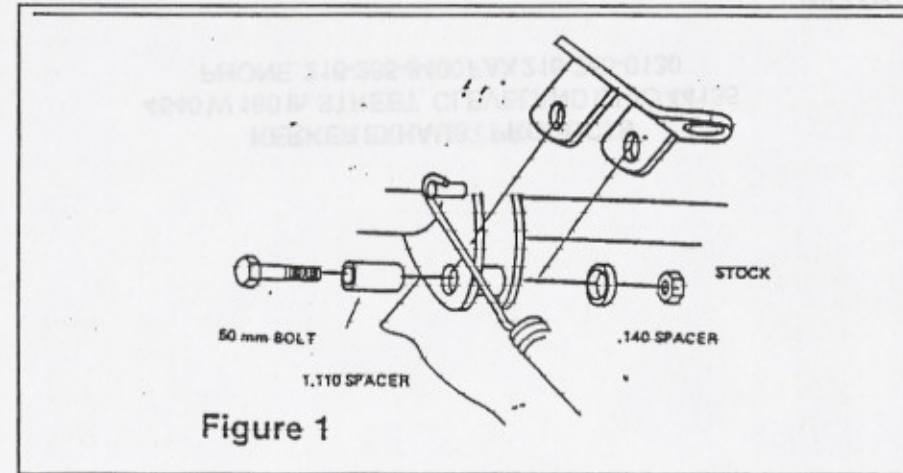

Fig 2

