

## USE AND WARRANTY DISCLAIMER

SuperTrapp Industries, Inc. of 4540 W. 160th Street, Cleveland, Ohio 44135 (SuperTrapp), warrants its SuperTrapp products against defects in factory materials and workmanship for one year from the date of purchase or until ownership in the product is transferred, whichever occurs first, subject to limitations below.

Under this warranty, SuperTrapp will repair or replace defective, covered parts, at option, or provide a replacement unit. SuperTrapp makes no warranty with respect to components of the SuperTrapp product not manufactured by SuperTrapp, including, but not limited to the following: clamps, nuts, bolts, packing, boots and hoses. Repair by SuperTrapp or replacement are the exclusive remedies under this written warranty or any implied warranty. SuperTrapp will not pay for the cost of removal or re-installation of the unit from any vehicle or for delivery and pick up of the unit. To obtain service under this warranty, the original purchaser must give specific written notice to his or her dealer within fifteen (15) days after discovery of any claimed defect in the unit, and must return such unit to the dealer within a reasonable time thereafter at the cost of the original purchaser.

This limited warranty is the only express warranty applicable to SuperTrapp product. Any implied warranty of merchantability or fitness for a particular purpose is limited in duration to the duration of this written warranty. Some states do not allow limitations on how long an implied warranty lasts, so the above limitation may not apply to you.

SuperTrapp shall not be responsible for any consequential, special or incidental damages of any nature including but not limited to the loss of use of any vehicle on which the unit may be installed and the cost of obtaining another substitute product. Some states do not allow the exclusion or limitation of incidental or consequential damages so this limitation or exclusion may not apply to you.

This warranty is valid only if proper size of the unit is installed, operated and maintained in accordance with factory instructions. This warranty does not cover any damage caused by (i) modification or alteration of the unit; (ii) improper installation, maintenance, operation or use; (iii) accident; (iv) servicing or repair by anyone other than SuperTrapp or its authorized agents.

**CAUTION!** Warranty does not cover chrome discoloration. You can minimize this problem by thoroughly cleaning and polishing the system before initial start-up, being sure the fuel mixture is not too lean, and preventing long periods of engine idle.

This warranty gives you specific legal rights and you may also have other rights which vary from state to state. Outside the United States, a different warranty may apply. For details, please contact your authorized SuperTrapp distributor.

*Since 1975, SuperTrapp has built a reputation on innovation and technical superiority. SuperTrapp® R&D is constantly designing, testing and improving; providing you with the latest in state of the art performance engineering. SuperTrapp® products are absolutely the best performance items available. They will provide years of trouble-free service.*

SuperTrapp® Industries, Inc.  
4540 W. 160th St. Cleveland, OH 44135  
Phone: (216) 265-8400 fax: (216) 265-0130



003-1809 07.07.09

## Installation Instructions



**IDSX™ Internal Disc Series**

## Polaris Ranger RZR-S 800

**835-1808** IDSX Slip-on Exhaust

## CAUTION!! PLEASE READ BEFORE PROCEEDING.

FAILING TO PROPERLY TUNE YOUR QUAD WILL VOID ANY WARRANTY ON THIS PRODUCT. Re-tuning the fuel system is essential not only to improve performance, but also to ensure durability of your quad. Typically, an exhaust system that is less restrictive than stock will require a richer fuel mixture. Many quads, especially ones manufactured after 1998, come from the factory with a lean air/fuel mixture due to EPA regulations. Many aftermarket products are available which allow you to properly tune your quad. Additionally, your OEM dealer will have products that will work adequately for your application. Proper tuning is best performed by a qualified technician. Call your local dealer for recommendations for your specific application.

### END CAP INSTALLATION:

See disc installation instructions. Then continue to step (2).

1. Holding the body with the mounting brackets pointing up, install the end cap. The outlet should be pointing down.
2. Align the threaded holes in the cap with the holes in the body and install the 1/4-20 button head screws and star lock washers supplied.

### STOCK SYSTEM REMOVAL:

1. Remove exhaust system from the expansion joint back. You will need to save the "doughnut" gasket for new system install

### IDSX INSTALLATION:

1. Apply two pieces of self adhesive heat shield tape to the air box as shown in FIGURE 2.
2. Remove nuts from stock bolts in rear sub-frame and install mount brackets, with washers, as shown in FIGURE 1. Install the bracket marked 029-1810 on the left and the bracket marked 029-1811 on the right. **DO NOT TIGHTEN.**
3. Install factory "doughnut" gasket onto new s-bend assembly so that the flat end is seated against the flange on the inlet of the pipe. Insert new s-bend assembly into the head pipe and fasten with two spring extensions, supplied in the hardware kit.
4. Install two rubber bushings and one spacer in each muffler mount bracket as shown in FIGURE 1.
5. Slide T-bolt clamp (supplied) onto the inlet of the muffler. Insert the muffler onto the s-bend assembly and install muffler using 5/16" x 2" bolts, washers, aluminum spacers, and nylock nuts as shown in FIGURE 1. Install right side first then the left side. **DO NOT TIGHTEN.**
6. Align the muffler and s-bend pipe to allow for proper clearance of the frame, and tighten the mount brackets, muffler mounts, and finally the T-bolt clamp.

**IMPORTANT:** After a short test ride, check and retighten all fasteners as necessary.

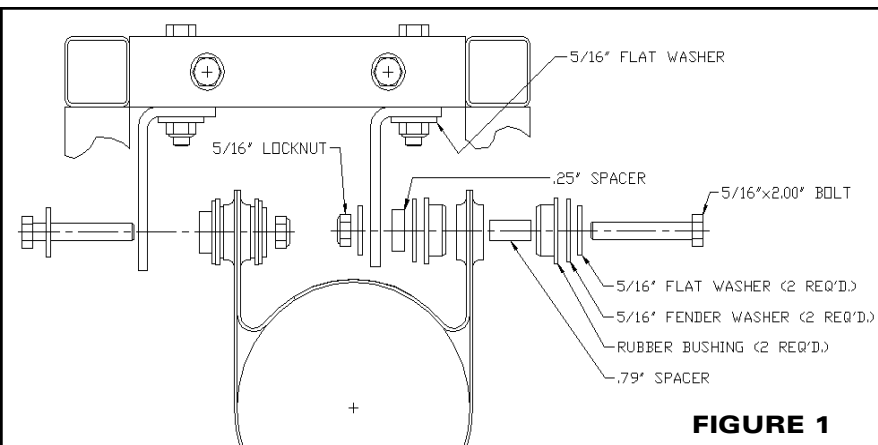

FIGURE 1



FIGURE 2

### GENERAL TUNING GUIDE:

The following will give you a base to work with in understanding how your SuperTrapp functions in relationship to the following parameters: POWER, SOUND, and JETTING.

Your system was supplied with 12 diffuser discs. On this model, 7 discs will work fine with stock jetting and air filter. We consider 6 discs the minimum to use; this will flow about the same amount of air as your stock system would. Using 9 or more discs will necessitate a jetting change.

*Example:* Let's say you start off with 7 discs and your quad runs fine, but you want more power. By adding discs you do three things: (1) the exhaust tone will get louder, (2) the motor will run leaner (carburetion), and (3) your horsepower and power band will go up. It's the opposite if you take discs out: (1) the exhaust tone will get quieter, (2) the motor will run richer (carburetion), and (3) the horsepower and power band will move down. The secret to performance tuning is knowing how to make parts work together. It is very difficult, even with sophisticated equipment, to determine absolute jetting

### DISC INSTALLATION:

1. Stack the recommended amount of discs with the end cap together aligning the three screw holes. Orient the discs so the flat surface of the discs will be against the core with the outer lip angled away from the core. (SEE DIAGRAM)
2. Insert the (3) screws through the end cap and disc stack and apply the high temp lube, supplied, to the threaded end of each screw.
3. Insert the entire assembly into the muffler using the supplied T-handle hex key, inserted into one screw head, as a handle. Align the (3) screws with the threaded inserts in the core. (SEE DIAGRAM)
4. Tighten the screws evenly in a cross pattern, SEE DIAGRAM. Discs should be tightened to 15-25 in/lbs or once the screw head contacts the end cap tighten 2 full turns.

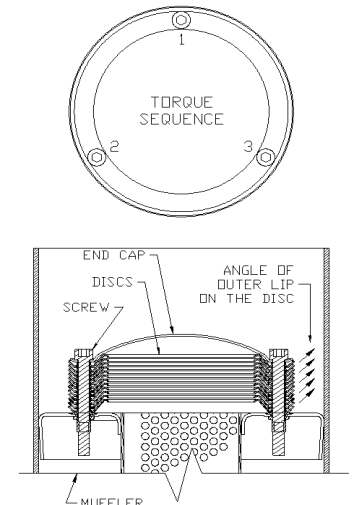

### CLEANING & MAINTENANCE

The IDSX system is manufactured from stainless steel. Stainless steel is used for its high strength at high temperatures and resistance to corrosion. Before you run your new SuperTrapp IDSX for the first time, clean all grease, fingerprints, and dirt from the entire system. (A good glass cleaner works well.) A clean, grease-free surface will allow even coloration. After a relatively short time of running, the IDSX will begin to take on a gold tint. The coloration will be relatively even throughout the entire system. The hotter you get the system, the darker it will become. Due to the unique properties of stainless steel, the care of the IDSX is minimal. Although, do not hesitate to use soapy water and a soft cloth to clean the surfaces. Scratches and abrasions can be removed by lightly sanding around the circumference of the parts (not the length) with 600 grit wet/dry sandpaper. A fine Scotch-Brite pad can then be used to remove any heavier sanding marks and restore the original hand buffed finish