

USE AND WARRANTY DISCLAIMER

SuperTrapp Industries, Inc. of 4540 W. 160th Street, Cleveland, Ohio 44135 (SuperTrapp), warrants its SuperTrapp products against defects in factory materials and workmanship for one year from the date of purchase or until ownership in the product is transferred, whichever occurs first, subject to limitations below.

Under this warranty, SuperTrapp will repair or replace defective, covered parts, at option, or provide a replacement unit. SuperTrapp makes no warranty with respect to components of the SuperTrapp product not manufactured by SuperTrapp, including, but not limited to the following: clamps, nuts, bolts, packing, boots and hoses. Repair by SuperTrapp or replacement are the exclusive remedies under this written warranty or any implied warranty. SuperTrapp will not pay for the cost of removal or re-installation of the unit from any vehicle or for delivery and pick up of the unit. To obtain service under this warranty, the original purchaser must give specific written notice to his or her dealer within fifteen (15) days after discovery of any claimed defect in the unit, and must return such unit to the dealer within a reasonable time thereafter at the cost of the original purchaser.

This limited warranty is the only express warranty applicable to SuperTrapp product. Any implied warranty of merchantability or fitness for a particular purpose is limited in duration to the duration of this written warranty. Some states do not allow limitations on how long an implied warranty lasts, so the above limitation may not apply to you.

SuperTrapp shall not be responsible for any consequential, special or incidental damages of any nature including but not limited to the loss of use of any vehicle on which the unit may be installed and the cost of obtaining another substitute product. Some states do not allow the exclusion or limitation of incidental or consequential damages so this limitation or exclusion may not apply to you.

This warranty is valid only if proper size of the unit is installed, operated and maintained in accordance with factory instructions. This warranty does not cover any damage caused by (i) modification or alteration of the unit; (ii) improper installation, maintenance, operation or use; (iii) accident; (iv) servicing or repair by anyone other than SuperTrapp or its authorized agents.

CAUTION! Warranty does not cover chrome discoloration. You can minimize this problem by thoroughly cleaning and polishing the system before initial start-up, being sure the fuel mixture is not too lean, and preventing long periods of engine idle.

This warranty gives you specific legal rights and you may also have other rights which vary from state to state. Outside the United States, a different warranty may apply. For details, please contact your authorized SuperTrapp distributor.

Since 1975, SuperTrapp has built a reputation on innovation and technical superiority. SuperTrapp® R&D is constantly designing, testing and improving; providing you with the latest in state of the art performance engineering. SuperTrapp® products are absolutely the best performance items available. They will provide years of trouble-free service.

SuperTrapp® Industries, Inc.
4540 W. 160th St. Cleveland, OH 44135
Phone: (216) 265-8400 fax: (216)265-0130



003- 7169 07.06.07

Kerker 3" Chrome 2:1 System Installation Instructions

**128-71570 FOR HARLEY-DAVIDSON FLST/FXST
SOFTAIL MODELS, With Oxygen sensors**

WARNING! This system is not complete without one of the following end caps:

Chrome tapered end cap	108-7257
Chrome fishtail end cap	108-8021
Chrome turndown end cap	108-8022

STOCK SYSTEM REMOVAL

1. Remove right side front footboard. (IF EQUIPED)
2. Loosen head pipe heatshields and remove exhaust flange nuts.
3. Disconnect electrical connections to O2 sensors.
4. Remove four bolts that mount the mufflers to the frame bracket.
5. Remove complete exhaust system. Save stock hardware.
6. Remove exhaust flanges from head pipes by removing retaining rings.
7. Remove both oxygen sensors from head pipe. Save for new system.

MUFFLER BRACKET INSTALLATION

1. Remove stock muffler mounting bracket (see figure 1A).
2. Install the Kerker muffler mounting bracket using 3/8"x2-1/4" bolts, 3/8 flat washers, and 3/8 lock washers supplied (see figure 1B).

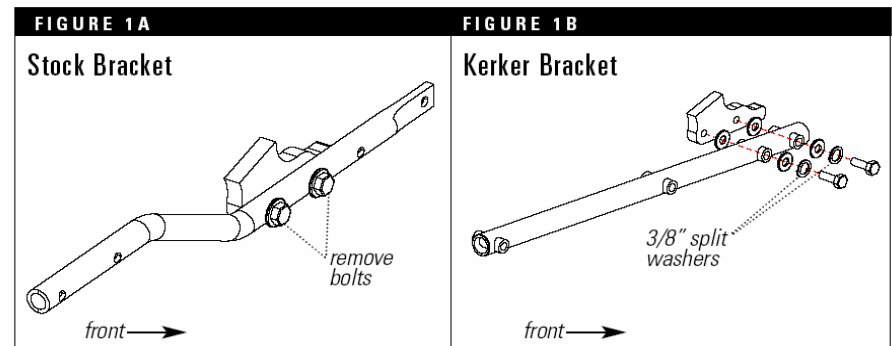

PRE-INSTALLATION NOTES

You must use the cone shaped exhaust gaskets, part number 65324-83A, available from your Harley-Davidson dealer. Do not use the flat type gaskets with our head pipe.

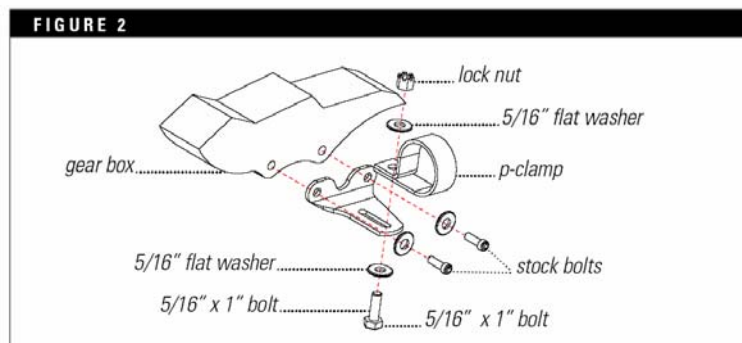

SYSTEM INSTALLATION:

1. Remove the two lower center gear box cover screws and install bracket using stock screws and washers (see figure 2). Clamp will be mounted later.
2. Install stock flanges using stock retaining rings.
3. Apply anti-seize to the threads of the oxygen sensors and install in new head pipe. (**VERY IMPORTANT*** Apply anti-seize to the threads of the oxygen sensors **ONLY**. Contamination of the sensor probe can adversely affect engine performance).
4. Install head pipe into exhaust ports using recommended cone shaped gaskets and stock flange nuts. **DO NOT TIGHTEN.**
5. Install heavy duty P-clamp, supplied, onto lower head pipe (see figure 2). Install 5/16" x 1" bolt with 5/16" washers and lock nut, all supplied. **DO NOT TIGHTEN.**
6. Install center bolt clamp, supplied, onto muffler inlet, and mount muffler to head pipe.
7. Align muffler with bracket and install (2) 5/16" x 1" bolts, flat washers, and lock washers to fasten muffler to bracket. **DO NOT TIGHTEN.**
8. Install the 5/16"x1.50" bolt with (2) 5/16" flat washers and nylock nut into the center bolt clamp. **DO NOT TIGHTEN.**
9. Check clearance on system and tighten system starting at the exhaust ports, then tighten gear mount and clamp. Tighten muffler inlet clamp, and muffler mounting bracket.
10. Install Kerker heatshields using hose clamps, supplied.
11. Re-install floorboard and tighten to manufacturers specs
12. Re-check all bolts after engine has been up to full operating temperature.

END CAP INSTALLATION

1. Remove end cap screws from mufflers.
2. Insert end cap lining up the screw holes.
3. Re-install and tighten end cap screws

IMPORTANT: CHECK AND RETIGHTEN ALL FASTENERS AFTER THE FIRST COUPLE OF RIDES, THEN AT EACH SCHEDULED MAINTENANCE.

ACCESSORIES & REPLACEMENT PARTS

When ordering accessories or replacement parts you may need the part number of this muffler. Please record the part number and date of manufacture here.

Part No. _____ Date of Manufacture _____

Fiberglass Replacement Kit (2 per muffler)	400-4020
Fishtail End Cap	108-8021
Turndown End Cap	108-8022
Tapered End Cap	108-7257