

ACCESSORIES & REPLACEMENT PARTS

When ordering accessories or replacement parts you may need the part number of this silencer. Please record the part number and date of manufacture here.

Part No. _____ Date of Manufacture _____

Fiberglass Repack Kit (2 per muffler)	400-4020
Tapered End Cap	108-7257
Turndown End Cap	108-8022
Fishtail End Cap	108-8021

CUSTOMER SERVICE

Call Dealership or Point of Purchase in which the exhaust was purchased for questions on returns, repairs, or fit and finish of SuperTrapp® products.

Call SuperTrapp® Customer Service for technical questions between 8am-5pm Eastern Time, (216) 265-8400, or by fax, (216) 265-0130.



Kerker® Chrome 2:1 System Installation Instructions

HARLEY-DAVIDSON FXST/FLSTN/FLSTF/FLSTC MODELS 128-78065 Chrome 2:1 System

WARNING! This system is not complete without two of the following end caps:

Chrome Tapered End Cap	108-7257
Chrome Fishtail End Cap	108-8021
Chrome Turndown End Cap	108-8022

STOCK SYSTEM REMOVAL

1. Remove right side front footboard.
2. Loosen headpipe heatshields and remove exhaust flange nuts.
3. Remove four bolts that mount mufflers to frame bracket.
4. Remove complete exhaust system. Save stock hardware.
5. Remove exhaust flanges from headpipes by removing retaining rings.
6. Remove front exhaust heat shield and hose clamps from rear shield.

MUFFLER BRACKET INSTALLATION

Remove stock muffler mounting bracket, (see figure 1A) and replace with Kerker muffler mounting bracket, (see figure 1B) using 3/8 x 2-1/4 bolts, 3/8 flat washer, and 3/8 lock washers (supplied).

Since 1975, SuperTrapp® has built a reputation on innovation and technical superiority. SuperTrapp® R&D is constantly designing, testing and improving; providing you with the latest in state-of-the-art performance engineering. This Kerker® Chrome 2:1 Exhaust System is the culmination of hundreds of hours of street, track and dyno- development. It will provide you with unmatched performance and lasting, trouble-free service.

SuperTrapp® Industries, Inc.
4540 W. 160th St. Cleveland, Ohio 44135 (216) 265-8400 fax. (216) 265-0130
e-mail. sales@supertrapp.com | www.supertrapp.com



003-7804 07.17.03

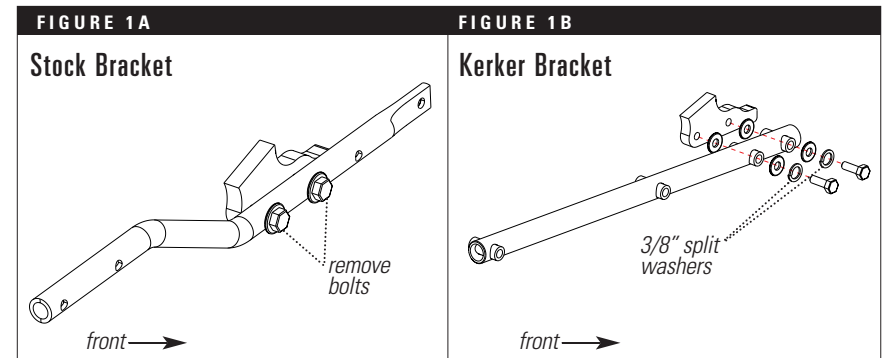
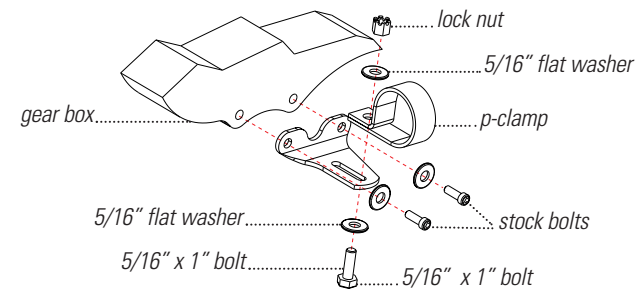

FIGURE 2



KERKER INSTALLATION

1. Remove two lower gear box cover hex head screws and install bracket using stock hex bolts and washers (see figure 2). Clamp will be mounted later.
2. Install stock flanges using stock retaining rings.
3. Install Kerker heatshields using Kerker hose clamps, both supplied.
4. Inspect exhaust gaskets and replace if necessary. Install headpipes into exhaust ports using stock nuts finger tight.
5. Install heavy duty P-clamp, supplied, onto lower headpipe (see figure 2). Install 5/16" x 1" bolt with 5/16" washer and lock nut, all supplied. **DO NOT TIGHTEN.**
6. Install T-bolt clamp, supplied, onto muffler inlet and mount muffler to headpipe and muffler bracket. Use 5/16" x 1" bolt rear muffler mount and 5/16" x 1-1/4" bolt with spacer on front mount. **DO NOT TIGHTEN.**
7. Check clearance on system and tighten system starting at the exhaust ports, then tighten gear box mount and clamp, muffler inlet clamp, muffler mounting bracket and heatshields.
8. Re-install floorboard and tighten to manufacturers specs.
9. Re-check all bolts after engine has been up to full operating temperature.

END CAP INSTALLATION

1. Remove end cap screws from mufflers.
2. Insert end cap lining up the screw holes.
3. Re-install and tighten end cap screws.

***IMPORTANT!** Please thoroughly check entire exhaust system to make sure that no hoses or wiring come in contact with exhaust system. Re-route any such components away from exhaust to prevent component damage or failure. Such damage could result in personal injury if not properly taken care of.*