

USE AND WARRANTY DISCLAIMER

SuperTrapp Industries, Inc. of 4540 W. 160th Street, Cleveland, Ohio 44135 (SuperTrapp), warrants its SuperTrapp products against defects in factory materials and workmanship for one year from the date of purchase or until ownership in the product is transferred, whichever occurs first, subject to limitations below.

Under this warranty, SuperTrapp will repair or replace defective, covered parts, at option, or provide a replacement unit. SuperTrapp makes no warranty with respect to components of the SuperTrapp product not manufactured by SuperTrapp, including, but not limited to the following: clamps, nuts, bolts, packing, boots and hoses. Repair by SuperTrapp or replacement are the exclusive remedies under this written warranty or any implied warranty. SuperTrapp will not pay for the cost of removal or re-installation of the unit from any vehicle or for delivery and pick up of the unit. To obtain service under this warranty, the original purchaser must give specific written notice to his or her dealer within fifteen (15) days after discovery of any claimed defect in the unit, and must return such unit to the dealer within a reasonable time thereafter at the cost of the original purchaser.

This limited warranty is the only express warranty applicable to SuperTrapp product. Any implied warranty of merchantability or fitness for a particular purpose is limited in duration to the duration of this written warranty. Some states do not allow limitations on how long an implied warranty lasts, so the above limitation may not apply to you.

SuperTrapp shall not be responsible for any consequential, special or incidental damages of any nature including but not limited to the loss of use of any vehicle on which the unit may be installed and the cost of obtaining another substitute product. Some states do not allow the exclusion or limitation of incidental or consequential damages so this limitation or exclusion may not apply to you.

This warranty is valid only if proper size of the unit is installed, operated and maintained in accordance with factory instructions. This warranty does not cover any damage caused by (i) modification or alteration of the unit; (ii) improper installation, maintenance, operation or use; (iii) accident; (iv) servicing or repair by anyone other than SuperTrapp or its authorized agents.

CAUTION! Warranty does not cover chrome discoloration. You can minimize this problem by thoroughly cleaning and polishing the system before initial start-up, being sure the fuel mixture is not too lean, and preventing long periods of engine idle.

This warranty gives you specific legal rights and you may also have other rights which vary from state to state. Outside the United States, a different warranty may apply. For details, please contact your authorized SuperTrapp distributor.

Since 1975, SuperTrapp has built a reputation on innovation and technical superiority. SuperTrapp® R&D is constantly designing, testing and improving; providing you with the latest in state of the art performance engineering. SuperTrapp® products are absolutely the best performance items available. They will provide years of trouble-free service.

SuperTrapp® Industries, Inc.
4540 W. 160th St. Cleveland, OH 44135
Phone: (216) 265-8400 fax: (216) 265-0130



003-7210 02.25.09



Installation Instructions

!!!IMPORTANT!!!

**PLEASE READ INSTRUCTIONS THOROUGHLY
BEFORE INSTALLING THIS EXHAUST SYSTEM.**



XR Series 2:2 Race System

815-71210 For Harley-Davidson® XR1200 Sportster® Models

REMOVAL OF STOCK SYSTEM:

1. Remove the stock exhaust system as described in your service manual. (Retain the flange nuts for the new system installation).
2. Remove the stock flanges from the head pipes and retain for the new system installation.
3. Remove the oxygen sensors from the front and rear head pipes and retain for new system installation.
4. Remove the drive pulley cover and exhaust mount bracket. (Retain the pulley cover and lower cover screw for the new system installation).
5. The exhaust gaskets should be replaced to achieve a proper fit and seal. Replacement gaskets are available from your Harley Davidson dealer, part number 65324-83A.

SYSTEM INSTALLATION:

1. Re-install the drive pulley cover using the stock fasteners only. You must place two 3/8" diameter x 1/8" thick washer (one per 3/8" bolt) and one 5/16" diameter x 1/8" thick washer (supplied) between the primary cover and the transmission case to compensate for the stock exhaust bracket that was removed.
2. Install the front mount bracket (large) to the back of the front mount point. Use the 5/16-18 x 2.25" bolt, 2 large 5/16" washers, small 5/16" washer and locknut. **See Figure 1 (DO NOT TIGHTEN).**
3. Install the rear mount bracket (small) to the front side of the rear stock mount point. Use the 5/16-18 x 2" bolt, 2- 5/16" washers, and locknut. **See Figure 2 (DO NOT TIGHTEN).**
4. Install the stock flanges on both head pipes.
5. Apply anti-seize to the threads of the oxygen sensors and install in new head pipes. (***VERY IMPORTANT*** Apply anti-seize to the threads of the oxygen sensor **ONLY**. Contamination of the sensor probe can adversely affect engine performance.)
6. Install the new front and rear head pipes using the stock flange nuts. (**DO NOT TIGHTEN**)
7. Install the mufflers onto the head pipes. (**DO NOT INSTALL TENSION SPRINGS**)
8. Align the rear muffler mount tabs with the rear mount bracket, position mount tabs as indicated in "Figure 2". Install the 5/16-18 x 1" bolt, (2) 5/16 washers, and a nylock nut (supplied). **See Figure 2 (DO NOT TIGHTEN)**
9. Align the front muffler mount tabs with the front mount bracket, position mount tabs as indicated in "Figure 1". Install the 1/2" spacer, 5/16-18 x 1 1/2" bolt, 2- 5/16 washers, and a nylock nut (supplied). **See Figure 1 (DO NOT TIGHTEN)**
10. Align both pipes and mufflers so they clear the engine and suspension. Tighten all fasteners starting at the exhaust port and working back to the mounting bracket.

11. Install (4) tension springs (supplied) from each muffler body to each head pipe.
12. Reconnect oxygen sensors to wiring harness.

IMPORTANT: CHECK AND RETIGHTEN ALL FASTENERS AFTER THE FIRST COUPLE OF RIDES, THEN AT EACH SCHEDULED MAINTENANCE.

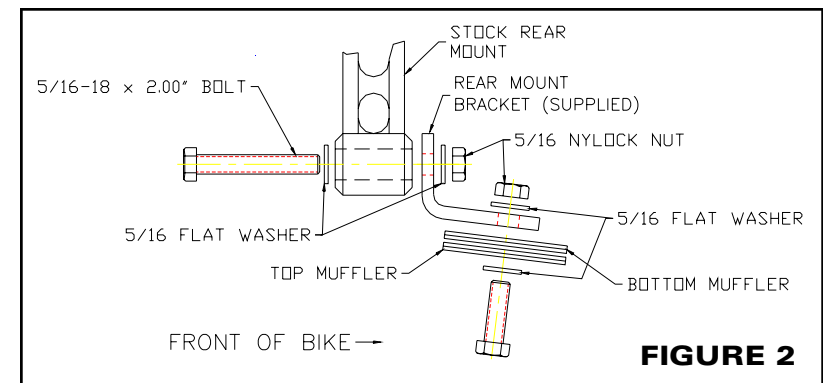
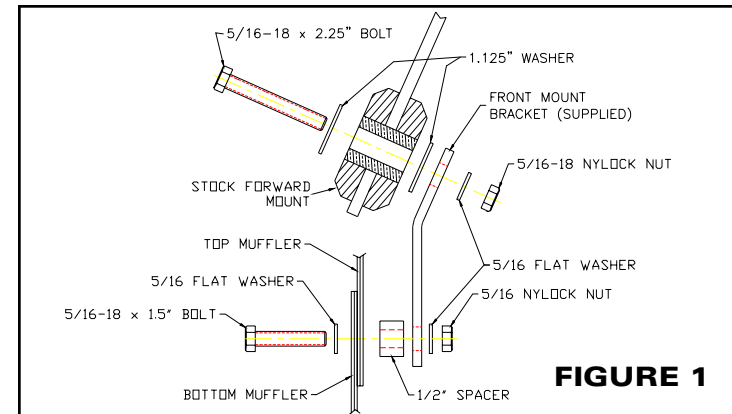

TUNING TIPS:

For maximum performance gains, we suggest using 16 discs and a free-flowing air filter kit with this exhaust system. As always, making performance modifications may affect the fuel delivery system of your motorcycle. It is recommended by Supertrapp to have your fuel delivery system tuned to ensure maximum performance and reliability. This work should always be performed by a certified technician.